

ASSEMBLED PRODUCTS® CORPORATION

IMPORTANT DOCUMENT - DELIVER TO MANAGER

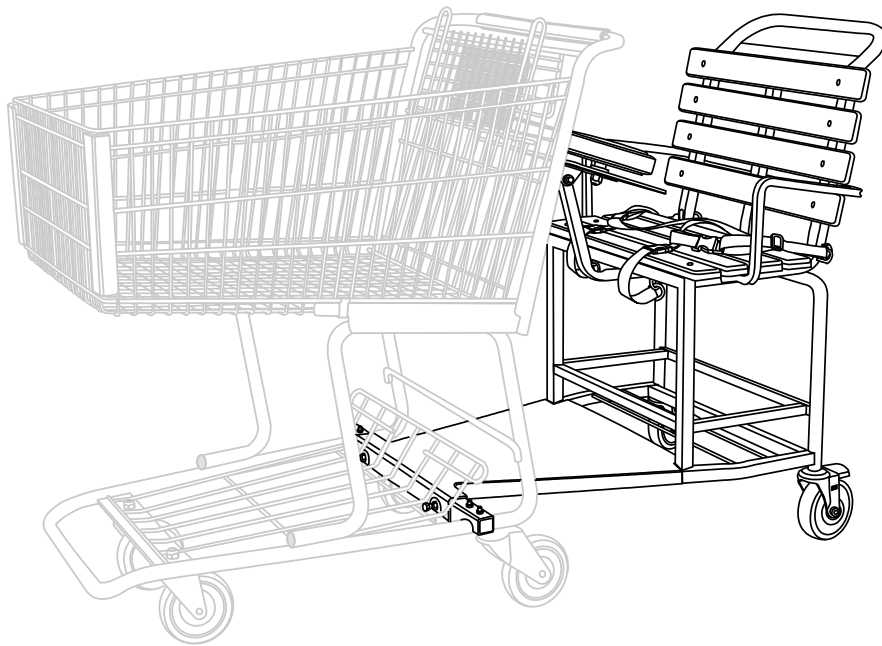

OWNER'S MANUAL



THANK YOU FOR PURCHASING THE SHOPPER'S AID CART ATTACHMENT. THIS PRODUCT IS INTENDED FOR THE USE AND ENJOYMENT OF ANYONE WITH CHILDREN OR PERSONS WITH LIMITED MOBILITY ASSISTANCE NEEDS. THIS CART IS NOT INTENDED FOR PERSONS WITH SEVERE IMPAIRMENTS. THEY SHOULD USE WHEELCHAIRS OR OTHER DEVICES SPECIFICALLY DESIGNED FOR THE DISABLED.

Shopper's Aid by Mart Cart® is a quality product line of Assembled Products™ Corporation

115 E. Linden • Rogers, Arkansas 72756 USA
(479) 636-5776 • Fax: (479) 636-3245
1-800-548-3373 www.martcart.com

CONGRATULATIONS!

You have just purchased one of the best shopping cart attachment on the market today. To assure you of the best and safest performance as well as longest life, please read the enclosed information. After reading this manual, should you have a service problem or need help, please call our customer service department with the serial number of your Shopper's Aid, at our toll free number: **1-800-548-3373 or (479) 636-5776**.

DAMAGE: Check the shipping carton for any visible damage. Report the damage to the freight carrier immediately. File a claim with the carrier if actual damage to your cart has occurred. Check the contents of the carton. The contents should agree with the information listed on the packing list. Report any discrepancy to the carrier and the factory immediately.

TO ORDER PARTS: Call **1-800-548-3373 or (479) 636-5776** or visit **www.martcart.com**

FREIGHT: All freight will be paid by the customer. Special consideration will be given to items under warranty coverage.

ATTENTION: It is the responsibility of the owner to maintain their Shopper's Aid in a safe and reliable operating condition at all times.

NOTE: Specifications found in this manual are subject to change without notice.

DAILY CARE INSTRUCTIONS FOR STORE PERSONNEL

1. CHECK BRAKES. BRAKES MUST LOCK SECURELY TO PREVENT CART FROM ROLLING WHILE A PERSON GETS ON OR OFF THE CART.
2. CHECK CHILD SEAT BELTS. REPLACE IF BROKEN OR DAMAGED.
3. CHECK ALL COMPONENTS. BE SURE TO CHECK FOR LOOSE BOLTS OR NUTS. REPLACE ANY BROKEN OR WORN PARTS.
4. CHECK ALL WARNING LABELS. REPLACE IF MISSING, WORN OR ILLEGIBLE.
5. CLEAN WITH WARM WATER AND A SOFT CLOTH.



SAFETY PRECAUTIONS

Please read before operation. Failure to heed warnings may cause severe injury.

- CART IS NOT INTENDED FOR CHILDREN INCAPABLE OF SITTING UNASSISTED.
- DO NOT PLACE INFANTS ON SHOPPER'S AID. THERE IS A SPECIAL BABY BOARD ATTACHMENT FOR INFANTS TO BE CARRIED ON THE SHOPPER'S AID WHILE BABY IS SECURED IN THEIR CAR SEAT.
- CHILDREN MUST WEAR SEAT BELTS AT ALL TIMES.
- SECURE BRAKES AND HOLD CART PRIOR TO ANYONE BOARDING SHOPPER'S AID.
- SECURE BRAKES AND HOLD CART WHILE PASSENGERS EXIT SHOPPER'S AID.
- DO NOT LEAVE CHILDREN UNATTENDED.



ASSEMBLING THE SHOPPER'S AID REQUIRES THE FOLLOWING TOOLS:

TWO 7/16" OPEN END WRENCHES & ONE 1/2" OPEN END WRENCH

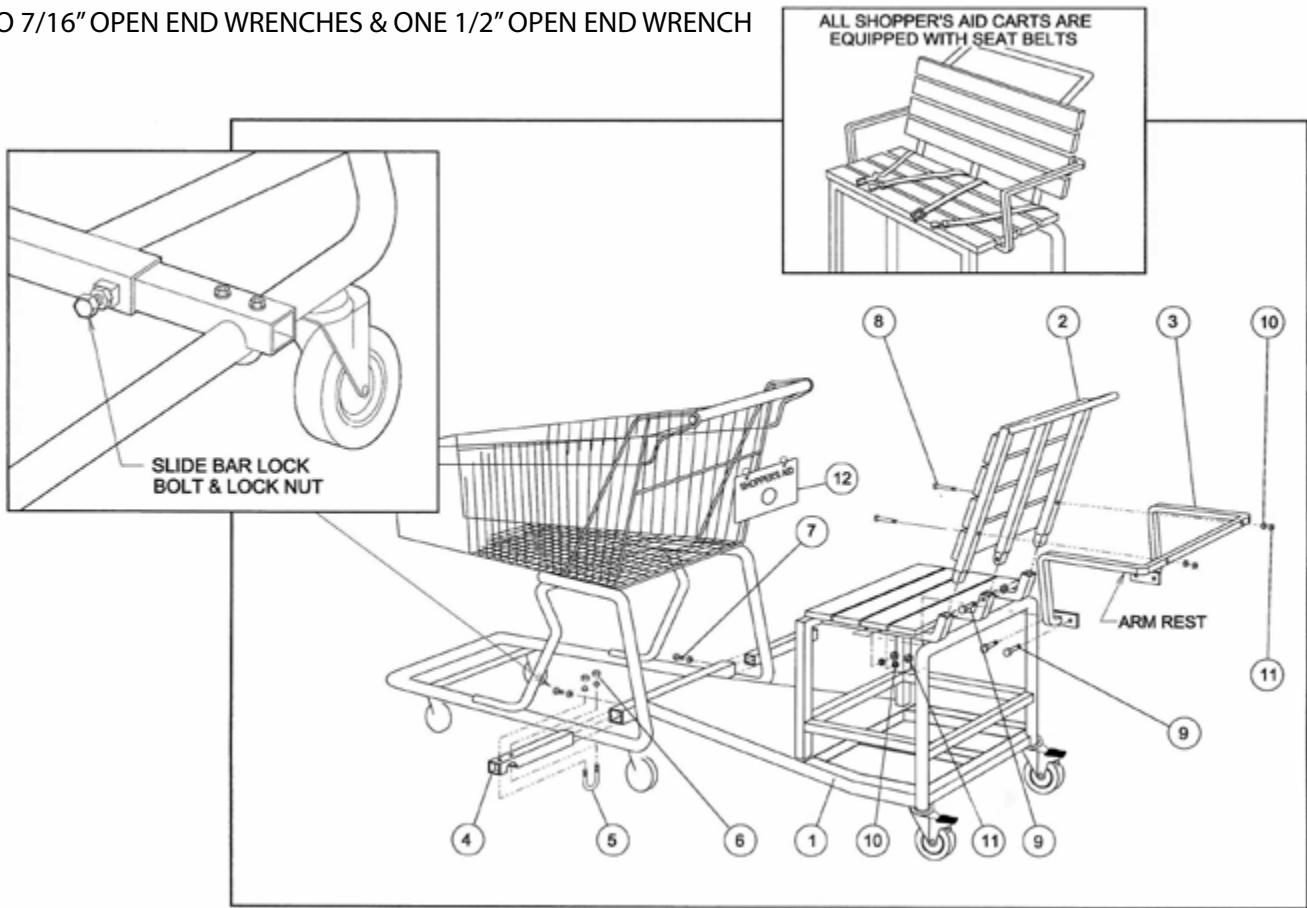

INSTALLATION INSTRUCTIONS

SHOPPER'S AID INCLUDES THE FOLLOWING PARTS

QTY	DESCRIPTION	ITEM
1	FRAME ASSEMBLY	1
1	SEAT BACK ASSEMBLY	2
1	ARM REST ASSEMBLY	3
2	SLIDE BAR ASSEMBLY	4
2	U-BOLT	5
4	5/16" LOCKNUT	6
2	5/16" BOLT W/LOCKNUT	7
2	1/4" X 2" BOLT	8
5	1/4" X 11/2" BOLT	9
7	1/4" FLATWASHER	10
7	1/4" NYLOC NUT	11
2	WARNING PLATE	12

ASSEMBLY INSTRUCTIONS

1. UNPACK ALL PARTS.
2. INSERT SEAT BACK (2) INTO FRAME (1). ASSEMBLE AS SHOWN.
3. INSERT BOLT (9) WITH WASHER (10) AND NUT (11), THEN TIGHTEN.
4. PLACE ARMREST ASSEMBLY (3) ONTO CART AS SHOWN AND INSERT BOLT (8) THROUGH SEAT BACK (2). INSTALL FLAT WASHER (10), LOCK NUT (11), AND TIGHTEN NUT.
5. PLACE BOLTS (9) THROUGH LOWER FLANGE OF ARM REST (3) AS SHOWN, INSTALL FLAT WASHERS (10) AND LOCK NUTS (11).
6. POSITION SHOPPER'S AID DIRECTLY BEHIND SHOPPING CART, LOOSEN BOLTS (7) OF FRONT BAR SO THAT SLIDE BARS (4) MOVE FREELY.
7. PLACE SLIDE BARS (4) ON TOP OF LOWER FRAME TUBES OF SHOPPING CART. MAKE SURE BARS ARE IN FRONT OF REAR CASTERS.
8. ATTACH SECURELY WITH THE U-BOLTS (5) PROVIDED.
9. POSITION SHOPPER'S AID SO THAT IT IS CENTERED DIRECTLY BEHIND SHOPPING CART. TIGHTEN BOLTS (7) ON BAR SO THAT SHOPPER'S AID CAN NOT SHIFT FROM SIDE TO SIDE. LOCK RETAINING NUT SO BOLT CANNOT LOOSEN.
10. ATTACH WARNING SIGN (12) TO BACK OF CART SO THAT IT IS CLEARLY VISIBLE TO THE CUSTOMER.



LIMITED WARRANTY

All **Shopper's Aid** parts are warranted for one year against defect, in material or workmanship. Labor is covered for **90 days** from **Date of Shipment**. Defective parts will be repaired or replaced by the company or its appointed agent. The warranty does not cover damage caused by misuse or negligence, nor does it cover defects or damages by use of unauthorized parts or service by an unauthorized person.



As shown with the Baby Board Attachment option

Shopper's Aid™ by Mart Cart® is a quality product line of Assembled Products™ Corp.

115 E. Linden • Rogers, Arkansas 72756 USA
(479) 636-5776 • Fax: (479) 636-3245
1-800-548-3373 www.martcart.com

